

Features

- ◆ Graphical user interface with touch panel for BACnet networks
- ◆ Fully compliant with ANSI/ASHRAE-135-2004 and ISO 16484-5 standard
- ◆ 5.7": 320x240 color LCD display
- ◆ Dimmable backlight, 256 colors (VGA)
- ◆ Representation of user defined graphics, numbers, text, bar charts, trend logs, and bitmaps
- ◆ Visualization and control of individual data points (Objects)
- ◆ Supports Alarming, Scheduling, and Trending; locally and by referring to remote BACnet schedule, and notification objects
- ◆ Supports common mathematical operations and functions as well as Boolean expressions
- ◆ Event-driven e-mail notification
- ◆ Access control with PIN code
- ◆ Simple, graphical programming with L-VIS configuration software supplied with the unit
- ◆ WYSIWYG preview on PC screen
- ◆ B-AAC (and in addition COV, Trending)
- ◆ Supports up to 512 BACnet server objects
- ◆ BACnet client configuration with L-VIS configuration software (scan and EDE import)
- ◆ BACnet client functions (WriteProperty, Read-Property, COV Subscription)
- ◆ Supports BACnet/IP or BACnet MS/TP
- ◆ Connector for external temperature sensor (L-TEMP)
- ◆ Digital Input e.g. for external light switch
- ◆ Aluminium frame with anodized finish
- ◆ Flush-mounting in combination with a mounting frame (LVIS-FRAME1)
- ◆ International protection rating:
Front: IP54 / Back: IP10
- ◆ Dimensions (5.7", LVIS-ME200):
W = 210 mm, H = 165 mm, D = 60 mm
- ◆ Supply Voltage: 9-24V AC or DC
- ◆ Ultra Low Power Consumption:
 - 3 W Display off
 - 8 W Display on

Description

L-VIS impresses with its timeless design, harmonic integration into modern and historical architecture as well as its extremely user friendly concept.

Primarily any information from a BACnet network can be displayed or controlled by the touch panel. Binary, analog, or multi-state objects (input, output, value) represent the

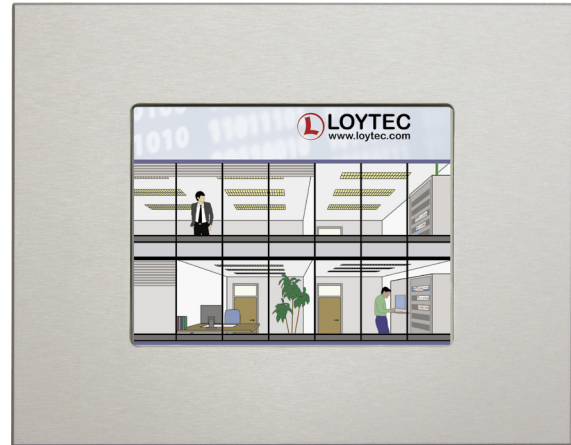

interface to the BACnet network.

The graphical interface can easily be adapted by using customized and detailed images or graphics in common file formats (*.JPG, *.BMP, *.TIF, etc. and even animated *.GIF). Any Information can be displayed in various ways. Dynamic information is shown as numerical values, changing icons, bar graphs or text.

L-VIS supports basic automation functions such as alarming, scheduling, and trending. This includes a local scheduling service as well as the possibility to configure several local and remote 24 hour schedulers through display elements. Thus L-VIS has the capacity to run as a standalone device or to interact with other L-VIS devices.

L-VIS also provides functionality to generate, deliver, acknowledge, and display alarm conditions and logs. Logged information is available through CSV file export.

The trending capability includes trend graphs, a data log of values and time stamps and transferring the recorded data to a host PC for analysis and for storage. Another helpful feature is the automatic transfer from the L-VIS recorded data to a preset destination.

Furthermore L-VIS supports common mathematical operations and functions, as well as boolean expressions.

L-VIS supports event-driven e-mail notification as a result of a predefined action triggered by a specific status or an exceeded high limit.

Order Number	Configuration
LVIS-ME200	5.7" Touch Panel 1 x BACnet MS/TP 1 x Ethernet (BACnet/IP)
LVIS-FRAME1	Mounting frame (5.7" model)
L-TEMP	External Temperature Sensor

L-VIS Application Example

The L-VIS touch panel presents valuable parameters from the network to service personnel and the end user. Any control command can be sent in order to e.g. move sun blinds, control cold-storage rooms, switch lights, lock doors, or open valves. The L-VIS can also be used in a switch cabinet. It can monitor and display important system parameters like energy consumption, alarms, or the temperature in cold-storage rooms. Additionally, L-VIS supports basic automation functions such as alarming, scheduling, and trending.

Remote Access and E-mail Notification

Remote access is supported via TCP/IP through an integrated VNC (Virtual Network Computing) server. The content of the L-VIS touch panel can be brought to a PC or PDA using the VNC protocol. Since VNC is platform independent, VNC viewers are available for several operating systems.

The L-VIS touch panel features event-driven e-mail notifications with predefined actions. Individuals are promptly informed about an abnormal status. Trend data are forwarded as an e-mail attachment, e.g. for LWEB-801 Server.

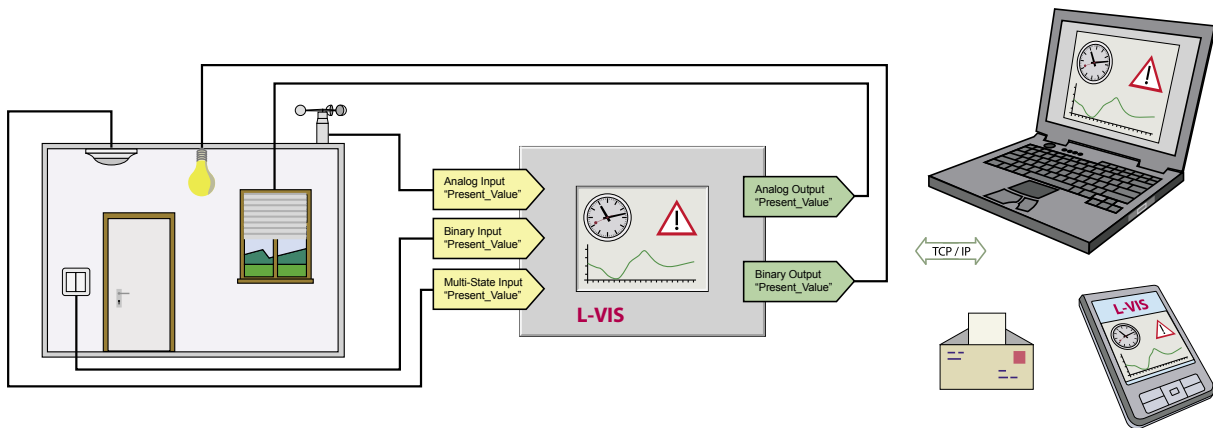

Easy Configuration

Easy configuration is guaranteed with the L-VIS configuration software supplied with the unit. An object-oriented configuration of the graphical interface with WYSIWYG preview and predefined functions make it easy and efficient to create a pleasing graphical interface. With the UCS-16 character set of the Unicode standard (ISO 10646), any language, including Chinese, Japanese, and Korean (CJK) is supported.

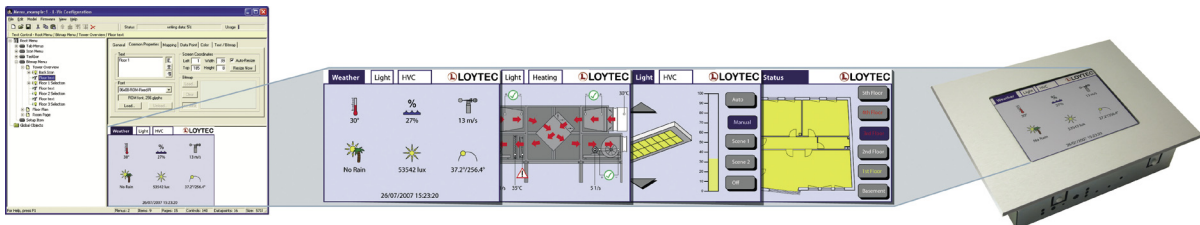

LC3020, L-Chip, L-Core, L-DALI, L-GATE, L-INX, L-IP, LPA, L-Proxy, L-Switch, L-Term, L-VIS, L-WEB, and ORION stack are trademarks of LOYTEC electronics GmbH. Other trademarks and trade names used in this document refer either to the entities claiming the markets and names, or to their products. LOYTEC disclaims proprietary interest in the markets and names of others.

LOYTEC reserves the right to make changes to these specifications without further notice for performance, reliability, production technique, and other considerations.